

Crankcase heater kit optimization for Reciprocating Compressors A, B, D, Q, S, TK and SK3

Everyday Frascold focuses its energies not only on creating new innovations, but also on passionately studying every detail of our existing compressors. The high quality of the products offered by Frascold lies in the great care and attention that the company's experts pay toward them.

In order to guarantee an even higher quality of our reciprocating compressor families A, B, D, Q, S, TK, and SK3, we have decided to introduce an optimization for crankcase heater kit.

The main features of this optimization are the following:

- The crankcase heater is fixed in place thanks to the use of a metal spacer and a magnet;
- The magnet magnetizes the spacer, ensuring an optimal adhesion to the surface of the compressor body;
- The magnet and spacer will therefore cover the protruding portion of the crankcase heater kit.

The drawings below show the details of this optimization:

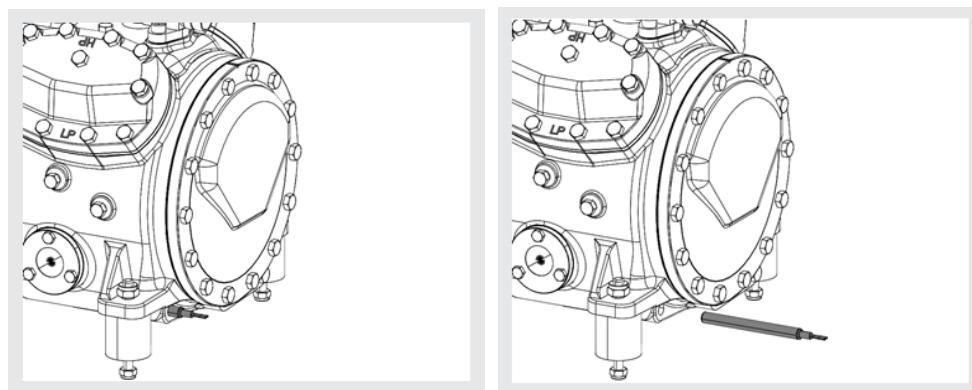

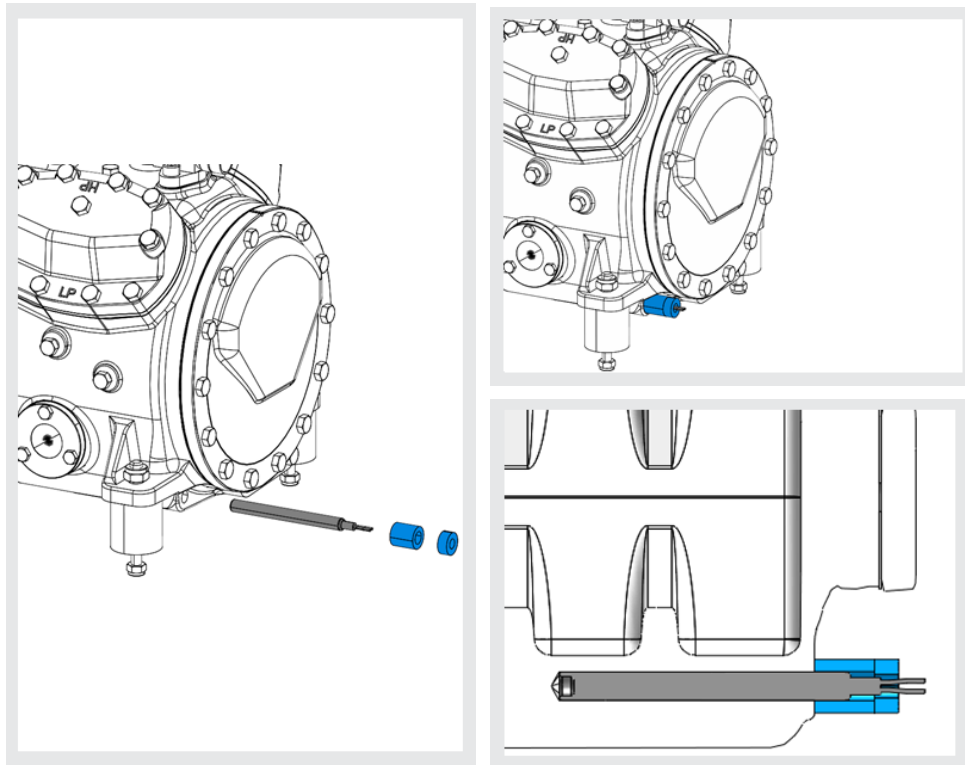

The main advantages of this newly implemented solution are the following:

- The placement of the crankcase heater in its seat is optimized, guaranteeing a high stability;
- The overall dimensions of the compressor remain unchanged.